



FASHION TROPHY | 2019-2020

“Style is a way to say who you are without having to speak.”

— Rachel Zoe

Fashion might be about following what's fashionable; Trends change as the ideologies and mind-set of the masses do but style is who you are and what defines you. These are some thoughts preached by thousands of fashion designers across the globe. Everybody has a style, a thing that is unique about you, therefore, style cannot be judged as good or bad, beautiful or ugly as it depends on the bearer. Fashion may change but style never fades away.

Style never goes out of Fashion.

Every Architect has a style, a unique technique or approach to design that is the very thing that defines the Architect and his/her architecture but what if the Architect had decided to pursue the field of Fashion instead of Architecture? What would be the creative output of an architect's mind applied to fashion design?

Analyse the style of a famous Architect and apply the same philosophies and ideologies to fashion design.

Evaluation Criteria:

- Theme and Brief's Interpretation
- Innovation & Creativity
- Choreography
- Execution of Performance & Co-ordination
- Costumes & Props

Rules and Regulations:

- Performance duration allotted to each institution is maximum 8 minutes for performance + 2 minutes for stage setup & clearance. If the stage is littered during a performance, participants are expected to clean the stage completely of all the debris.
- Narration of not more than 30 seconds must be presented within time slot allotted.
- Negative marking would be done for exceeding the given time limit.
- A minimum of 7 and a maximum of 11 participants + 4 back-stage helpers are permitted.
- Substituting participants or any other last-minute modifications will not be entertained/ allowed, once a final list of performing students is received and verified.
- Short listed entries must submit their soundtrack on the first day of the convention prior to competition in their own CD/flash drive. The track should be in an uncompressed format.
- Essential props are permitted (SAFETY TO BE ACCOUNTED) if they are an integral part of the performance.
- Any misconduct such as exposing identity through college name, participant(s) name or college code anywhere will be DISQUALIFIED.
- The decision of the jury will be final.
- Vulgarity and offensive performance or behaviour will result in disqualification.

Shortlisting/Screening Requirements:

- An HD quality video (minimum 720p) of not less than 3 minutes and not more than 5 minutes is to be submitted through NASA India website www.nasaindia.co/trophy by the Unit Secretary of the college at the time of online submission.
- The screening should include narration of storyline/ main theme of the performance.

Results will be sent via email to the Unit Secretaries after screening process.

Important Dates:

The Release of brief: 1/1/2020
Registrations open: 1/1/2020
Registration closes on: 7/1/2020
Submission deadline: 15/1/2020

Stage Specifications:

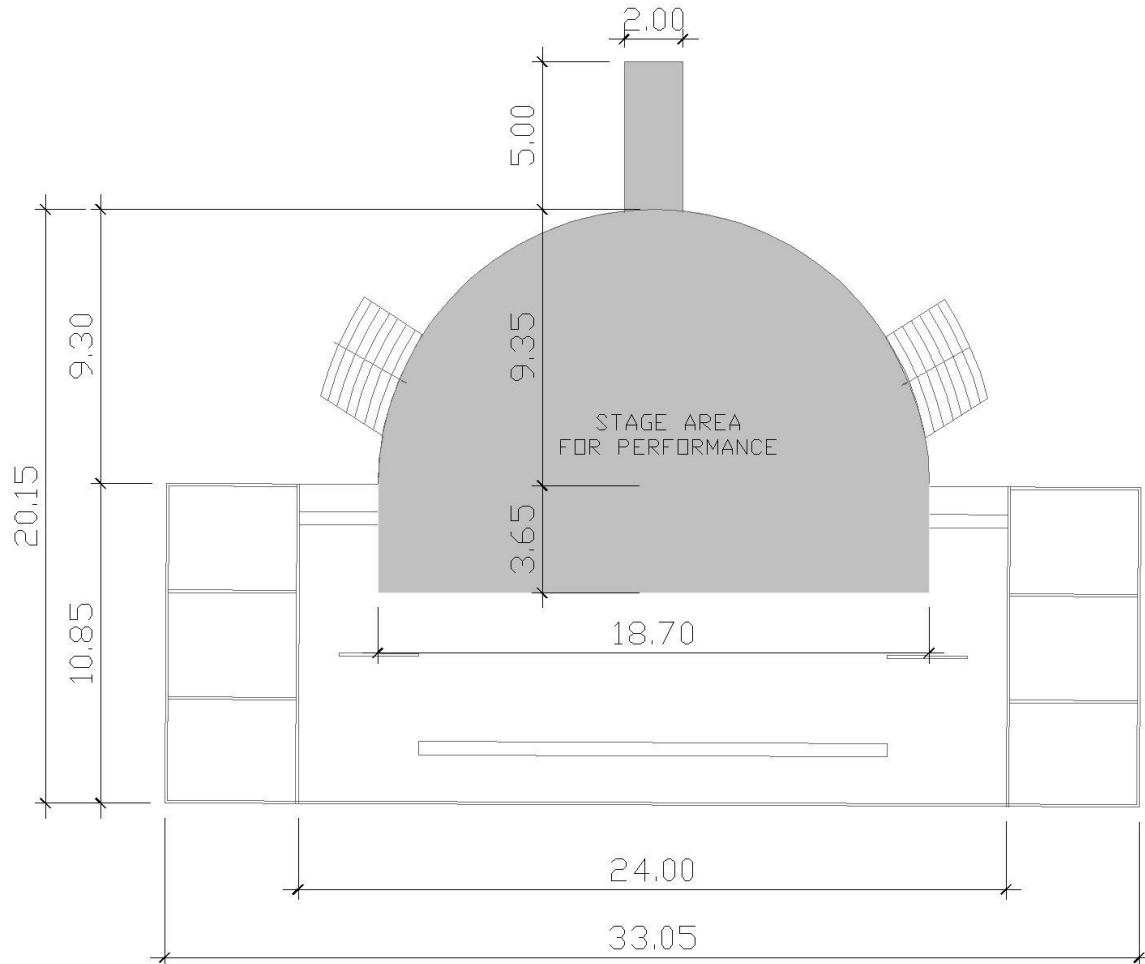

All Measurements are in Meters

Any Kind of Queries need to be submitted through

<https://nasaindia.co/trophy>

to

Syed Khwaja Abid

National Secretary | 2019-2020

NASA India

National Association of Students of Architecture

Fashion Trophy | 2019-2020

EMBARK

